

FIREPLACE, WOOD BURNING STOVE SUPPLEMENT

ATTACH PHOTO -- COMPLETE IN FULL		
APPLICANT	POLICY/QUOTE NUMBER	
FIREPLACE INSERT COMPLETE QUESTIONS 1-6	FIREPLACE (BUILT-IN) COMPLETE QUESTIONS 1-4	FREE STANDING FIREPLACE &/OR STOVE COMPLETE QUESTIONS 1-6
1. TYPE OF HEATING EQUIPMENT <input type="checkbox"/> Built-In Fireplace <input type="checkbox"/> Free Standing Fireplace <input type="checkbox"/> Free Standing Stove <input type="checkbox"/> Furnace Supplement <input type="checkbox"/> Other: _____		
2. IS THIS UNIT A MAJOR HEAT SOURCE FOR THE DWELLING <input type="checkbox"/> Yes <input type="checkbox"/> No		
3. WERE CHIMNEY AND EQUIPMENT INSTALLED BY CONTRACTOR <input type="checkbox"/> Yes <input type="checkbox"/> No		NAME AND ADDRESS IF OTHER THAN THE HOME BUILDER
4. CHIMNEY INFORMATION - TYPE OF CHIMNEY <input type="checkbox"/> Masonry with tile flue liner <input type="checkbox"/> Prefab'd metal chimney (UL approved) <input type="checkbox"/> Other _____		
WHEN WAS CHIMNEY LAST CLEANED		HOW OFTEN IS CHIMNEY CLEANED
CLEANED BY WHOM		
<input type="checkbox"/> Insured <input type="checkbox"/> Chimney Sweep* <input type="checkbox"/> Contractor*		
*NAME AND ADDRESS		
IS MORE THAN ONE UNIT VENTED INTO THE SAME CHIMNEY FLUE		
<input type="checkbox"/> Yes <input type="checkbox"/> No		
THE FOLLOWING QUESTIONS SHOULD BE ANSWERED FOR FREE STANDING FIREPLACES AND/OR STOVES.		
BRAND NAME		YEAR PURCHASED
5. DOES YOUR FREE STANDING HEATING UNIT HAVE THE MINIMUM CLEARANCES OF: <input type="checkbox"/> Yes <input type="checkbox"/> No 36" between the stove box and any unprotected combustible surface in all directions <input type="checkbox"/> Yes <input type="checkbox"/> No 4" between stove and floor <input type="checkbox"/> Yes <input type="checkbox"/> No Pad under stove (see diagrams below)		
6. STOVE PIPE INFORMATION - DIAMETER OF PIPE		DISTANCE FROM THE NEAREST COMBUSTIBLE SURFACE
ARE PIPE SECTIONS OR JOINTS FASTENED WITH METAL SCREWS <input type="checkbox"/> Yes <input type="checkbox"/> No		DOES THE PIPE PASS THROUGH FLOOR, WALLS OR CEILINGS <input type="checkbox"/> Yes <input type="checkbox"/> No
IF SO, IS IT PROTECTED WITH A		
<input type="checkbox"/> Ventilated thimble <input type="checkbox"/> Fuel connector <input type="checkbox"/> Fire stop spacer		
IS MORE THAN ONE UNIT VENTED INTO THE SAME CHIMNEY		
<input type="checkbox"/> Yes <input type="checkbox"/> No		
DATE	/ /	INSURED'S SIGNATURE
		X

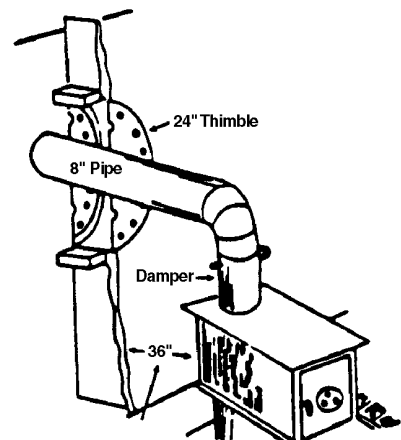
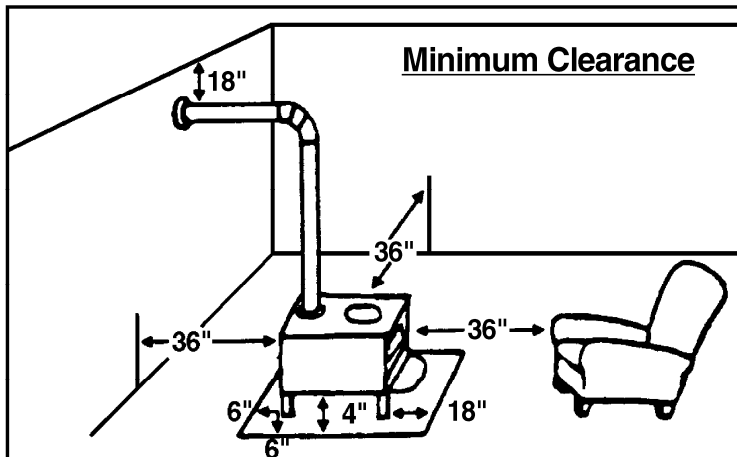

THESE CLEARANCES CAN BE REDUCED IF YOUR FLOOR OR COMBUSTIBLE WALL IS PROTECTED BY BRICKS WITH MORTAR OR BY METAL COVERED ASBESTOS STOVE BOARD. THE PAD UNDER YOUR STOVE SHOULD EXTEND 18" BEYOND THE ASH REMOVAL DOOR OR YOUR STOVE.